



Suitable for Dairy Products



Site Survey



Special Installation



TAVIRA II 100F



TAVIRA II 100F

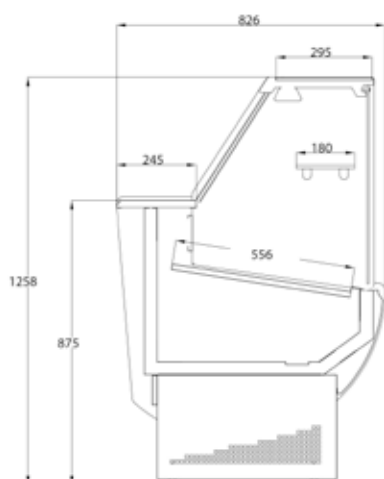

Understorage To Rear

Product Features

- Fully automatic
- Static cooling
- Adjustable feet
- Interior light with switch
- Digital controller and temperature display
- Ambient shelf
- Acrylic sliding doors to display area
- Hinged door to refrigerated understorage
- 13 Amp socket to rear for scales/till etc.
- Stainless rear shelf and deck
- Storage doors: 100 = 1, 130 = 1, 150 = 1, 200 = 2

Technical Specifications

Temperature Range (°C)	+2 to +8
Refrigerant	R290
Type of Defrost	Off Cycle
Exterior Finish	White
Interior Finish	Stainless steel
Power	13 Amp
Max Ambient	25°C at 60% RH
Climate Class	3

	Ext. Dimension (WxDxH) (mm)	Net Weight (kg)	Energy Cons. (kWh/year)	Input Power (W)	Display Area (m ²)	Energy Class
TAVIRA II 100F	980 x 826 x 1258	123	1494	250	0.6	
TAVIRA II 130F	1280 x 826 x 1258	144	1680	342	0.8	
TAVIRA II 150F	1480 x 826 x 1258	158	1746	401	0.96	
TAVIRA II 200F	1980 x 826 x 1258	182	2076	530	1.24	